

GARTEC STRATEGOS SUPERIOR STEP LIFT

By MPR



ABOUT

The Gartec Strategos superior step lift is galvanized as standard but can also be hot galvanised, powder coated in any RAL colour, or a stainless steel version is available as an option.

Made for outdoor as well as for indoor use, It is reliable, with minimal builders work and no pit required. There is a flexible fixing attachment arrangement to the wall to assist with some minor building discrepancies. A freestanding steel framework is also an alternative option (lifting height between 500-3000mm).

A safety plate under the step lift car provides great reliability and prevents accidents. Hand winding lowering comes as standard with automatic lowering optional. Sides and doors are made of impact-resistant safety glass. Aluminium floorboard comes as standard, with various vinyl and carpets as optional. No additional space is required to house any extra machinery as the motor is contained within the step lift.

OPTIONS

- Through or adjacent entry
- Bellows or safety plate
- Soft start / stop
- Different floor coverings
- Door automation
- Powder coating to alternative RAL
- Various alternative actuators
- Glass panes instead of polycarbonate
- Freestanding steel framework for installation

SUITABLE APPLICATIONS

Ideal for public spaces such as, local authority, retail, small office buildings, education, health, care homes and leisure.

TECHNICAL DETAILS

Type of Lift	Step platform lift for public, commercial and residential environments
Platform Dimensions	1100 x 1460mm as standard, (1100 x 1260mm and 1100 x 1660mm as optional)
Environment	Internal and external
Travel*	500mm - 3000mm
Rated Speed	0.08m/s
Capacity	400kg
Drive	Electrical motor / Screw and nut
Motor	3.0 kW Motor
Electrical Supply	Single phase 50 hz, three phase 50 hz optional,
Fuse	16 Amp, lockable isolator
Control Voltage	24 Volts
Compliance	BS6440, Machinery directive, Approved document M, Equality Act

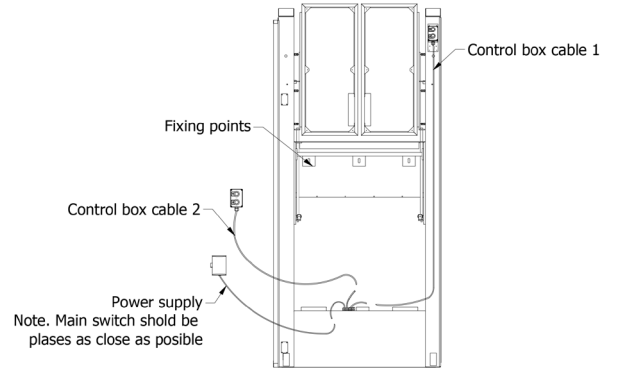
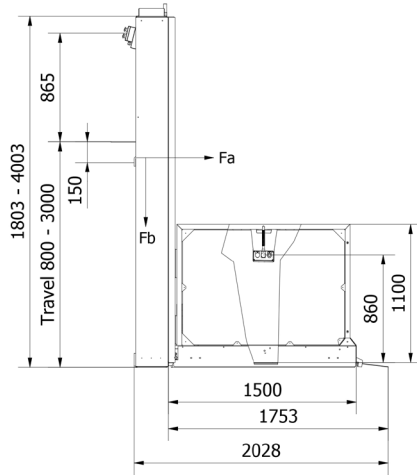
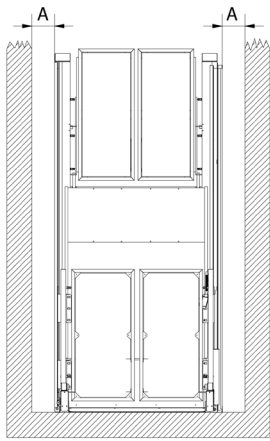

CLEARANCES

"A"
Horizontal distance between the platform and the wall 145mm if smooth, 355mm if irregular

Anchor
Horizontal & Vertical 3 pcs minimum, see installation information for further details of substrate requirements and type (Only use the fixation angles on the upper level)

Platform floor finish
Standard - Aluminium chequer plate

Electrical supply (Main switch)
1ph L, N, PE, 3 x 2,5mm², 16A

Technical Data
Rated capacity: 400kg / 2 person
Speed: 0,08m / s
Drive: 3,0kW Electrical motor / Belt drive
Electrical Connection: Single phase, 3 x 2,5mm²
Control voltage: 24 Volts
Soft start / Stop by frequency inverter
Drive system: Screw / Nut

HORIZONTAL FORCES	
Fixing height mm	Total Anchor Force Fa, kN
400	25,8
600	17,2
800	12,9
1000	10,3
1200	8,6
1400	7,4
1600	6,5
1800	5,7
2000	5,2
2200	4,7
2400	4,3
2600	4
2800	3,7

Fb= Vertical force of 10kN spread over area of 1300 x 250mm

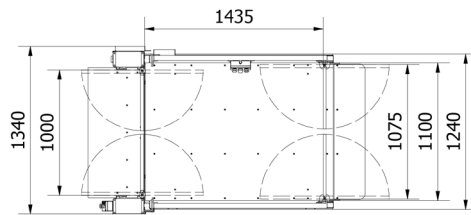
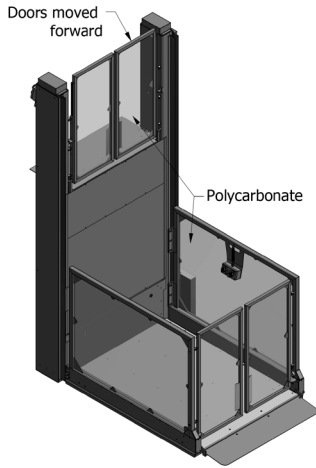

All of our MPR step lifts are supplied with 12 months product warranty and 12 months maintenance and servicing as standard.

THROUGH ENTRY AVAILABLE WITH SUPPORT FRAME

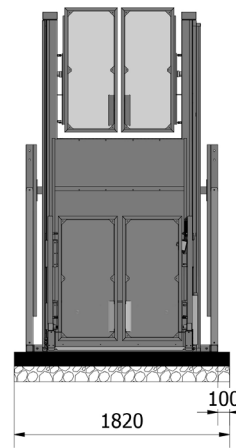
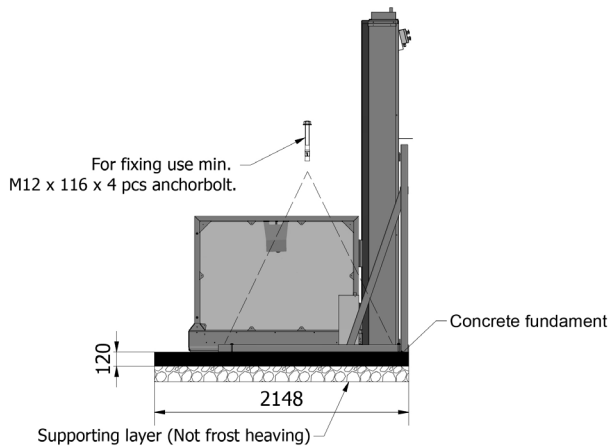

ADJACENT DOOR OPTIONS AVAILABLE

