

GARTEC

ARITCO

HOMELIFT

ACCESS



GARTEC HOME LIFTS

Gartec was founded with a clear aim, to become the leader in platform lift solutions with a hassle-free experience, making buildings more accessible, opening up possibilities and options for users. One of our key objectives is to use our expertise and knowledge so that we can deliver exceptional service. The use of well-designed lift products has led us to shape the industry and become an award-winning business.

OUR PROMISE TO YOU

With over 30 years history and industry knowledge we provide an easy experience, every time. Our purpose is to provide the right solution to our customers, helping people to live better. Our reliability and consistency is what makes us a popular choice for platform lift products and we always look at ways to continuously improve to support our customers needs.



“Both our Architect and Building Manager found the Gartec team professional, organised and proactive, and the installation process went smoothly. All the people my husband and I have dealt with have been helpful, and any queries dealt with quickly. The end result is totally integral to the build and reflects the modern architectural style.” Hazel, Brentwood

ABOUT HOME PLATFORM LIFTS

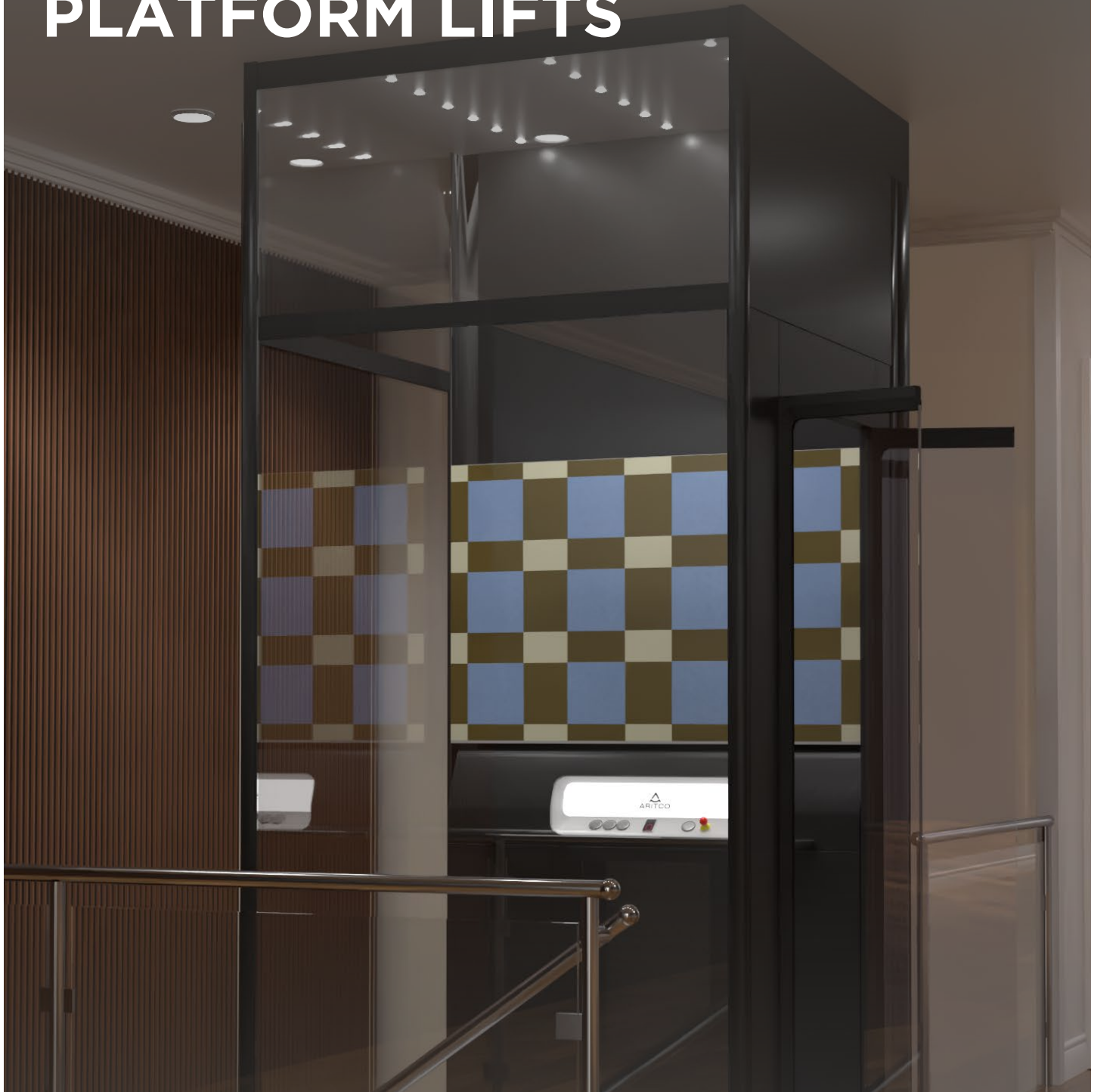

Home lifts are becoming ever more popular across the UK with people looking to future proof their homes, provide access for family and friends or just to make life easier on a day to day basis, helping taking items up and down such as the laundry, vacuum or suitcases.

Platform lifts lend themselves extremely well to residential applications as they come complete with their own shaft enclosure, requiring only a small footprint and with no pit or overrun. Being easily installed in just a few days generally with only

a small amount of builders and site preparation works required, helps to keep a project cost-effective. Using the latest technology and a good design they provide a safe and reliable addition to your home helping to promote health and well-being.

HOMELIFT ACCESS



ABOUT

The Gartec HomeLift Access has been designed for residential installations. Using our patented screw and nut technology, the lift is driven via an energy efficient electric motor, all of which is integral, therefore no separate machine rooms or pump boxes are needed. With multiple safety features and many customisations it's the perfect inclusion to any project giving your home the extra finishing touch.



KEY FEATURES

- Multiple lift sizes
- Shaft enclosure supplied with lift
- Glazed or solid shaft panels
- Doors on up to 3 different sides
- Single or double glass, half height gate or fire rated doors available
- Safety edges around platform
- 50mm pit or ramp
- Integral electrical cabinet

BENEFITS

- Optimal design and size, with a wide range of finishes
- Energy efficient (low power usage)
- Patented screw/nut technology
- Low maintenance and operating costs
- Minimal building work & quick installation
- Self-contained unit (no separate machine room)

CARRIER

The platform as standard, is delivered with a side wall (half height) including the control panel. This can be used for lifts with an open shaft, half height doors or when cost must be kept down. Height 1100mm.

Panels around and under the control panel are painted in RAL 9016 (Traffic White) as standard, but can be painted in any RAL colour as an option. The lighting at the floor of the platform and the control panel is 50 LUX.

FULL HEIGHT WALL

To get a conventional lift feeling the lift can be delivered with a full height wall (2,100mm high) as an option. The full height wall has a big mirror that goes along the whole machine side. The mirror has an integrated LED light. Included as standard for full height wall.

Panels around and under the control panel are painted in RAL 9016 (Traffic White) as standard but can be painted in any RAL colour as an option. The full height wall is available for platform sizes with machine side 1,040mm, 1,280mm and 1,480mm. When ordering a full height wall for platform 900x1,040mm, the electrical cabinet must be external.



DESIGNWALL

The full height wall can also be delivered with DesignWall instead of the mirror. It's a design feature which gives the customer an opportunity to personalise the lift with an artwork, creating a piece of art in his/her home.

The DesignWall is available with eight different artworks, created by Scandinavian designers and artists.

The artwork is placed behind a glass panel and there is no light in the DesignWall. It's available for lifts with platform size 1,040mm, 1,280mm and 1,480mm.

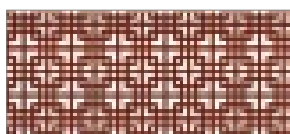

ORIENTALIC
BY ALEXANDER LERVIK



PINK
BY LOTTA INGMAN



ORANGE
BY LOTTA INGMAN



DIAGONAL
ALEXANDER LERVIK

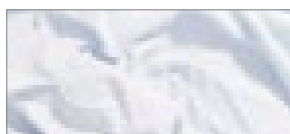

SHEETS
BY RIKARD LILJA



STRUCTURE
BY RIKARD LILJA

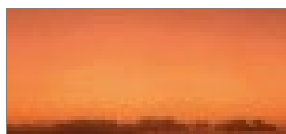

KEY WEST
BY ERIK UNDEHN

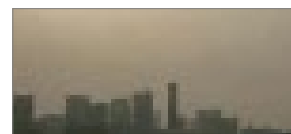

SKYLINE
BY ERIK UNDEHN



GEOMETRIC CLASSIC
BY EVELINA KROON &
ALEXANDER LERVIK



GEOMETRIC PINK
BY EVELINA KROON &
ALEXANDER LERVIK

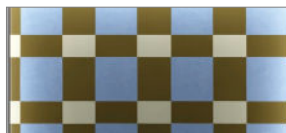

GEOMETRIC
BY EVELINA KROON &
ALEXANDER LERVIK



FOLD DOWN SEAT

In solid birch and with chromed brackets. The seat has to be folded back manually after use. This can be ordered as an option. Size: 320mm x 400mm. Not available for 900mm x 1,040mm.

CONTROL PANEL



ABOUT

Fully lit, the control panel consists of destination buttons, an emergency stop button, an alarm button, a telephone or auto-dialler, landing indicator (optional), max weight and number of people allowed.

CONTROL PANEL BUTTONS

32mm blank destination buttons. Optional 32mm buttons with text/numbers and braille for enhanced accessibility.

EMERGENCY STOP BUTTON

An emergency stop button is fitted for emergency situations. The light will indicate if pressed down.

ALARM BUTTON

The alarm button can be used in emergencies, this can be connected to an external alarm sounder or auto-dialler (optional) for additional safety.

EXTERNAL ALARM SOUNDER

When the alarm button is pressed the external alarm sounder (optional) will give a loud signal outside the lift.

TELEPHONE / AUTO-DIALLER

A means of communication is required from inside the lift. As standard a telephone handset is fitted on the platform below the control panel and is connected to the landline coming into the property. Any number can be dialled.

The auto-dialler is integrated in the control panel and it can be preprogrammed with up to 5 numbers. By pressing the alarm button for 10 seconds it will call

out to the programmed numbers. When unanswered, the next number is called. If a landline is not available a GSM unit can be supplied for both options.

HANDRAIL

With integrated LED lights, lighting up the floor, the handrail has a glossy surface to protect against wear and tear. It comes painted in RAL 9016 Traffic White as standard, when the platform is ordered in another colour than the standard Traffic White the handrail will be painted in grey (Anodic colour Natura).

LANDING INDICATOR

A digital display positioned at the control panel shows the floor the lift is on. Here additional safety information can be displayed such as, battery warnings, a bell when the alarm button has been pressed, number of starts and total run time since installation, a weight symbol, and a fire symbol when connected to the buildings fire alarm (optional).

KEY SWITCH ON PLATFORM

An optional key switch can be located on the control panel will lock the platform buttons prohibiting unauthorized use, this can be connected to either all destination buttons or to only one destination button.



“ Our experience with Gartec was good, Gartec were informative, friendly and professional, offering a quick turnaround using a high-quality lift solution. It was important to have lifts within each of the four townhouse due to them being four storey and also one that would complement the design and quality of the rest of the houses. The Gartec lifts offered this and only required a short installation period carried out by two friendly engineers. I am pleased with the overall look of the lifts installed and they will contribute to the townhouses being desirable to a bigger market. We look forward to working together again.”

Keith, Bellwood Homes

DOORS AND OPTIONS

ABOUT

We have a wide range of options and features available to suit your home, from buttons and different doors, to colours and floor finishes. With over 30 years of history, we have worked with hundreds of companies and homeowners finding the right lift solution that's perfect for each project, matching our lifts to brand colours or colour schemes, and finishes to compliment the building, we have a lift for every project and options and additions for you to choose from below.

DOORS



LARGE GLASS DOOR



DOUBLE DOOR



HALF HEIGHT DOOR



FIRE & SMOKE PROOF DOOR

HANDLES

DOOR HANDLES

As standard the doors are painted in grey (Anodic colour Natura) that looks like aluminium. For lifts ordered with door blades in the standard colour RAL 9016 (Traffic White) it is possible to order the door handles in the same colour as an option. Both the grey and white door handles will have a glossy surface to protect them from wear and tear and from getting dirty.

ACCESS

THRESHOLD AND RAMP

For all lifts installed without a 50mm recess, a door threshold in oak or stainless steel is delivered with the lift. A ramp can be supplied for access to the lift. The ramp is made of checkerplated galvanized steel.

AUTOMATIC DOOR OPENER

Press the button on the landing call station and the lift door opens. Internal concealed openers on GL & double saloon doors and externally mounted opener box on heavier fire doors.

OPTIONS & ADDITIONS

FLOORING

Choose from the following options for vinyl (standard), or Bolon (optional) flooring. It is possible to order the lift without a flooring which enables you to put in your own flooring (maximum thickness of an externally selected floor is 3mm).



DARK GREY VINYL

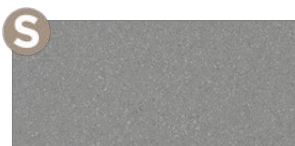

LIGHT GREY VINYL

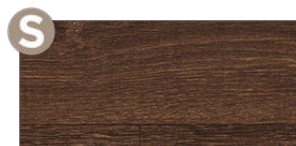

AGED OAK VINYL



OILED OAK VINYL



EUROPEAN OAK VINYL

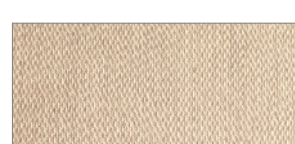

BOLON SISAL PLAIN SAND



BOLON FLOW STREAM



BOLON GRAPHIC GRADIENT

OPTIONAL RAL COLOUR RANGE

The lift comes painted in Traffic White RAL 9016 as standard. As an optional extra the walls, doors and console can all be elected from one of the common colours below. On request the 213 colours from the RAL K7 classic chart can be selected.

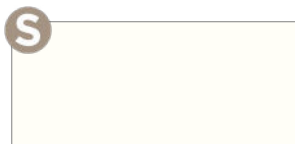

TRAFFIC WHITE
RAL 9016



PURE WHITE
RAL 9010

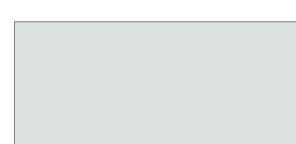

GREY WHITE
RAL 9002

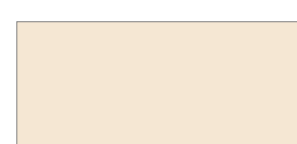

OYSTER WHITE
RAL 1013



LIGHT IVORY
RAL 1015



MOSS GREEN
RAL 6005



BROWN RED
RAL 3011



WHITE ALUMINIUM
RAL 9006



TELEGREY 1
RAL 7045



ANTHRACITE GREY
RAL 7016



JET BLACK
RAL 9005

PLEASE NOTE:
The actual colour of the lift may differ from the colour samples pictured.

DOOR CONTROL

LANDING CALL STATION

Standard call button placed on door frame. Back light in red and green for arrival indication.

KEY LOCKING

A key can be used to call and use the lift instead of a button to restrict access. The doors lock 10 seconds after closing.

PUSH BUTTON & KEY SWITCH

The key can be used to lock on/off the call button preventing unauthorised use.

REMOTE CALL STATION

Mounted away from the lift, either flush or surface mounted. Allows the user to call the lift whilst away from the doors.

WALLS & SHAFT

GLAZING TINTS (DOORS & SHAFT)

For doors and shaft, clear glass (JT0) comes as standard, or optional tinted glass (JT16) can be selected.

SHAFT PANEL COLOURS

Shaft panels are painted in 9016 (Traffic White) as standard. A range of common colours can be applied to shaft panels, console wall, door blades and door frames (option).

LIGHTING

CEILING LED DOWNLIGHTS

Built in LED strip downlights as standard.

SMART APP & SMARTFLEET

Aritco HomeLift Access is connected via the Aritco SmartApp giving you easy access to valuable information about the status of your lift and when it needs a service. The App in connection with a service contract and Aritco SmartFleet will ensure the lift continues to run smoothly, reliably, and with complete peace of mind.

ARITCO SMART APP FEATURES

- Safety Status
- Lift usage statistics
- Lift information
- Floor lock

ARITCO SMARTFLEET

The lift is connected to the Aritco SmartFleet platform providing 24 hour monitoring. With real time data from the lift, alarm notifications can be monitored and troubleshooting can be carried out remotely.

SMARTFLEET KEY FEATURES

- Remote monitoring
- Alarm notifications
- Status and usage reporting
- Live lift status

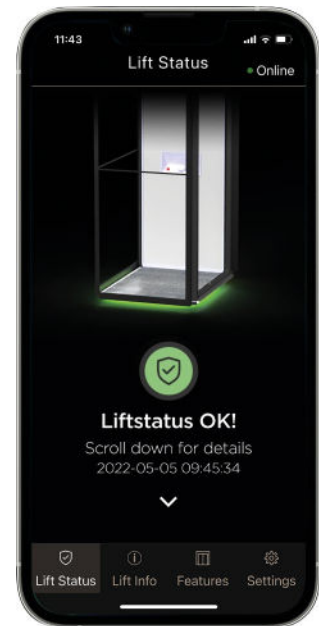

"I would like to say that everyone at Gartec has been very helpful. The lift is my lifeline and enables me to live here." Barbara, Stourbridge

DIMENSIONS

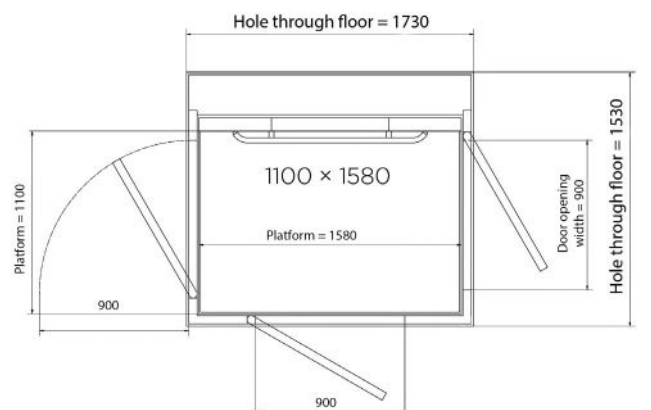
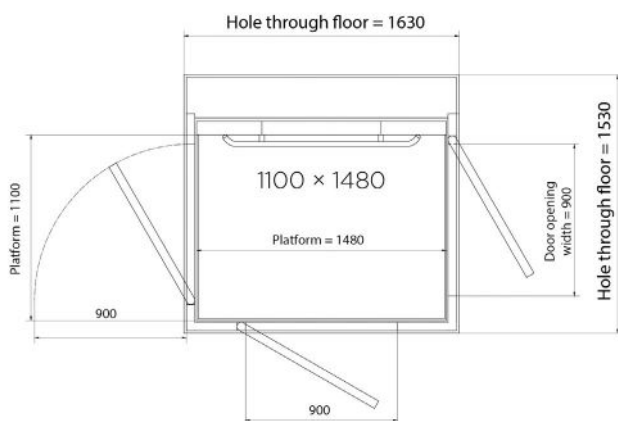
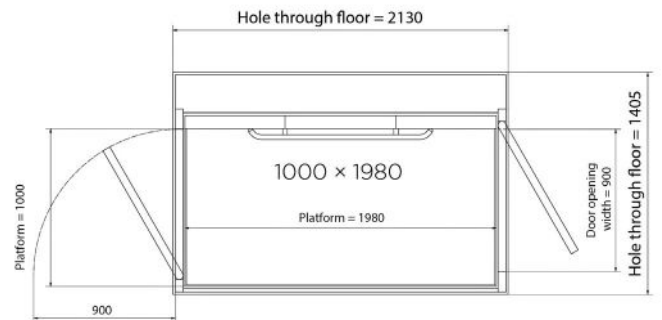
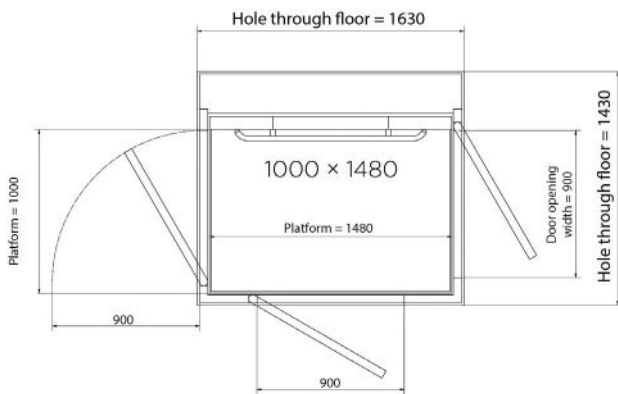
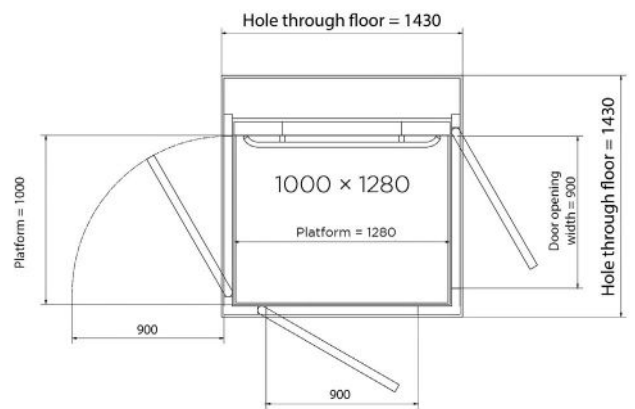
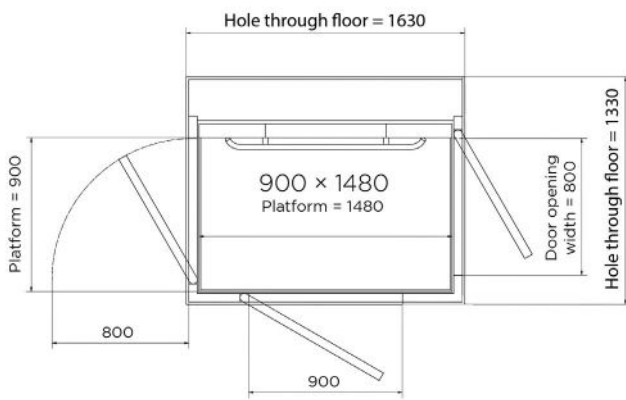
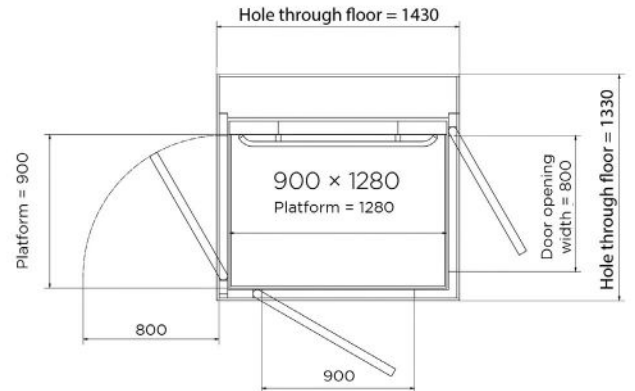
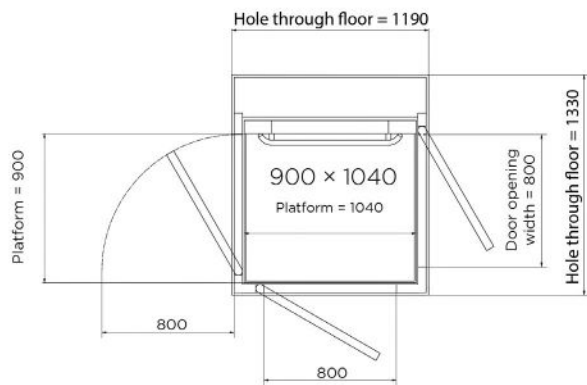

TECHNICAL DETAILS

Type of Lift	Passenger & light goods enclosed platform lift intended for use in residential environments
Compliance	European Machine directive 2006/42/EC European standard EN 81-41
Drive System	Patented screw/nut system
Rated Speed	Max 0,15m/s
Travel Height	250mm - 13,000mm
No. Floors	2-6
No. Doors per floor	Max. 2 doors per floor
Pit / Ramp	50mm (no pit is required when there is a ramp)
Entry	One, two or three sides
Top Height	2240mm (2140 or 2040mm possible with special hight doors) 1100-1600mm with half height gate (travel < 3000mm)
Platform Controls	Hold to run, the destination button must be kept pressed down during the whole ride
Landing Controls	One touch call, single press operation
Environment	Internal
Emergency Lowering	Battery operated emergency lowering
Control Voltage	24V
Motor	2.2kW
Door Locking system	Electrically operated deadlock
Power Supply	1-phase 230V 50 Hz 20 A type C MCB 3-phase 400V 50 Hz 20 A type C MCB
Rated Load	250, 410 or 500kg (dependent on platform size)
Enclosure	Solid panels or glass (optional)
Doors	GL Full height door as standard EI60 fire doors (optional), half height available (under 3000mm travel only)

DIMENSIONS

* Please note that a 3Phase power supply is required for 500kg lifting capacities

Platform Size	Rated Load	Structural Opening*
900 x 1040mm	250kg	1330 x 1190mm
900 x 1280mm	410kg	1330 x 1430mm
900 x 1480mm	410kg	1330 x 1630mm
1000 x 1280mm	410kg	1430 x 1430mm
1000 x 1480mm	410kg	1430 x 1630mm
1000 x 1980mm	500kg*	1405 x 2130mm
1100 x 1480mm	410KG/500kg*	1530 x 1630mm
1100 x 1580mm	500kg*	1530 x 1730mm

HOW THE LIFT WORKS

Platform lifts are a simple and safe way to travel between floors. Aritco lifts are completely contained within their own shaft. They operate using the patented screw and nut technology driving the platform with a reliable, quiet & efficient motor. Two guide rails run from top to bottom on the back of the lift. The platform is connected to the guide rails ensuring a smooth ride is provided. There is no requirement for hydraulic oil, a pump box or a separate machine room which can make it a more cost effective solution.



ENERGY-EFFICIENT

The Aritco HomeLift Access uses advanced technology to reduce energy consumption by up to 30%, helping to lower running costs and support more sustainable homes.

EMERGENCY BATTERY LOWERING

A secondary motor is fitted to the lift and connected to a battery. In the event of a power failure the lift switches to battery operation and allows the user to return to the floor below and exit the lift without any external assistance. From outside the lift it can be driven up or down via the small external control box.



SCREW & NUT TECHNOLOGY

Our patented screw and nut technology drives the lift up and down. A threaded bar runs up the back of the drives the lift up and down. A threaded bar runs up the back of the shaft and a nut which is attached to the platform, is driven up and down by a quiet and reliable motor.

Automatic lubrication of the screw is included as standard. It is connected to a sensor and timer, so an indicator advises when levels are running low.



PLATFORM & TRAVEL

The platform that you stand on and the DesignWall are the only parts that move as you travel up and down. The walls are static, and you see these move past as you travel. To start moving, you hold down the button on the control panel. When you let go, the lift stops moving, meaning you can change direction mid-travel. Around the perimeter of the platform is a safety edge which stops the lift from moving when pressed down due to an obstruction.

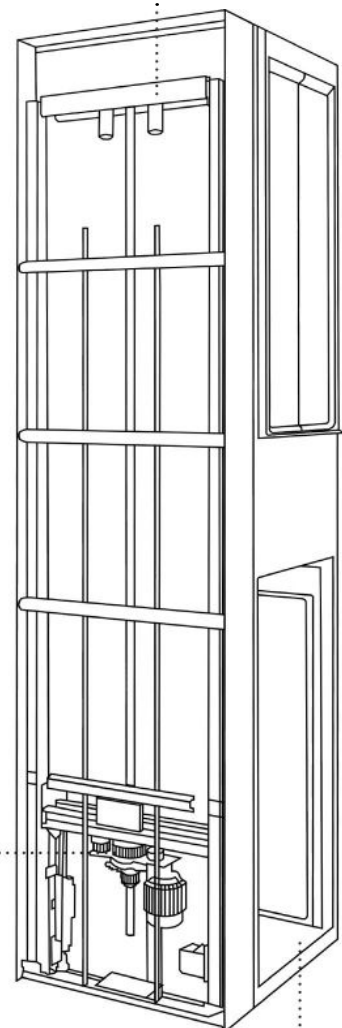

WARRANTY

Comes with a 60 months warranty. The screw and nut assembly has a 10 year warranty.

OUTDOOR VERSION

Aritco HomeLift Access Outdoor lift is designed for outdoor use. All outdoor lifts are delivered with guide rails in corrosion class C5.

The outdoor version consists of different options that enable an outdoor installation. Depending on the installation environment, different options must be added and the installation conditions that are specified must be followed.

VENTILATION FANS

Ventilation fans mounted on top of the shaft. 2 axial fans 240 V, 12 W. The fans are connected to an external power socket 230 V. The fans are mandatory for outdoor lifts.



ROOF

If the lift is not installed in an external shaft an outer roof must be used. One roof corner is left open for water outlet. The roof is made of galvanised steel and painted in RAL9016 (Traffic White) as standard. An inner ceiling with light must be ordered for outdoor lifts when ordering a roof.

DOOR CANOPY

A sloping roof placed above the landing doors to protect them from rain and snow, etc. The door canopy is made of galvanised steel and painted in RAL9016 (Traffic White) as standard.

HEATER

A heater placed in the bottom of the shaft is recommended for cold climates and can be ordered as an option. The heater must be connected to an external power socket. Note that for cold climates less than -5 the lift must be installed in an external heated shaft.



CONTACT US:

01296 397100
sales@gartec.com
www.gartec.com

GARTEC